

ПРЕДПРИЯТИЕ МАКСАЭРО

- Производство воздуховодов и систем вентиляции
- Клапаны противопожарные
- Клапаны дымоудаления
- Вентиляторы общепром, дымоудаления, крышные

220056, г. Минск, ул. Стариновская, 15

Тел./факс: +375 17 244-67-44, 258-67-51, 347-73-56, 252-54-27

Velcom: +375 29 603-88-99

E-mail: olegaero@yandex.by

www.maxaero.by



Блок розжига SIT 537 ABC

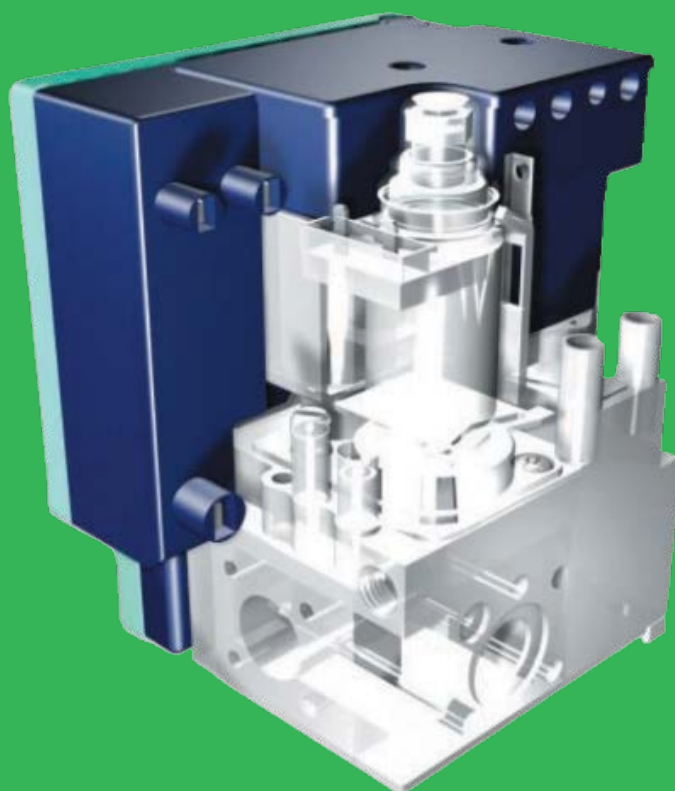

537 ABC

DESCRIPTION

The 537 ABC is an electronic flame safety device for controlling a gas appliance using the principles of flame rectification.

The 537 ABC automatic device has been designed for domestic gas appliances with or without a fan in the combustion circuit; with direct ignition or ignition by means of an intermittent pilot in applications which require either non-volatile or volatile lockout. The 537 ABC family of products has been specifically designed for fixing on SIT 840, 845 and 848 SIGMA multifunctional controls by means of an exclusive plastic container which integrates itself with the valve body and simplifies connection of the solenoid valves.

APPLICATIONS

The 537 ABC is an automatic ignition control for applications with intermittent operation in accordance with EN298 for:

- boilers with natural draught
- boilers with forced draught including dynamic control of the air pressure switch.

NORMATIVE REFERENCE

EN 298

Automatic gas burner control systems for gas burners and gas-burning appliances with or without fans.

BASIC FEATURES

- Compact design
- Direct assembly on the gas control
- Incorporated igniter
- Direct burner ignition (DBI) or by intermittent pilot (IP)
- Manual reset function and remote signalling of the non-volatile lockout state
- Multiple plug-in connectors
- Utilises well established electronic technology for high reliability of operation
- Precise and repeatable timing
- Flame detection by ionization
- EC approval according to EN 298 standard
- Repetition of the cycle after loss off flame during operation
- Permanent lock-out visualization, a without thermostat input being present
- Suitable for applications at low ambient temperatures

Options available

- Fan and air pressure switch control
- Volatile lockout version for specific applications
- Possibility to connect an automatic safety thermostat in series with the solenoid valve with manual lockout following its operation
- Different flame current sensitivity options may be specified
- Protection rating IP44
- Several pre-purge and safety timings can be tailored to the application.

OPERATION

Normal operation (natural draught or fan assisted)

During the waiting or purge time, T_w or T_p , the unit verifies that there is no parasitic flame signal present, and that the internal circuitry is operating correctly. If the unit is used on a fan-assisted application, the air pressure switch is verified to be in the N.C. (normally closed) or "no flow" position.

Upon powering the fan, the unit will not begin the operating sequence until the N.O. (normally open) or "flow" position is activated on the air pressure switch. After the scheduled waiting time T_w , or purge time T_p , the built-in igniter and the gas valve are energized. This commences the safety time, T_s . The ignition spark will ignite the gas and the flame will be sensed by the HV electrode.

Upon sensing the flame, the HV spark will be suppressed and the gas valve will remain energized. When the thermostat is satisfied, the valve and fan are de-energized and the control returns to the stand-by mode. The safety time of the 537 ABC has a constant duration in all operating conditions and, in particular, does not depend on the moment the pressure switch is switched over.

Resetting the unit

To reset the unit the reset switch is depressed. If a first reset is not successful, wait at least 10 seconds before the next attempt.

WIRING DIAGRAM

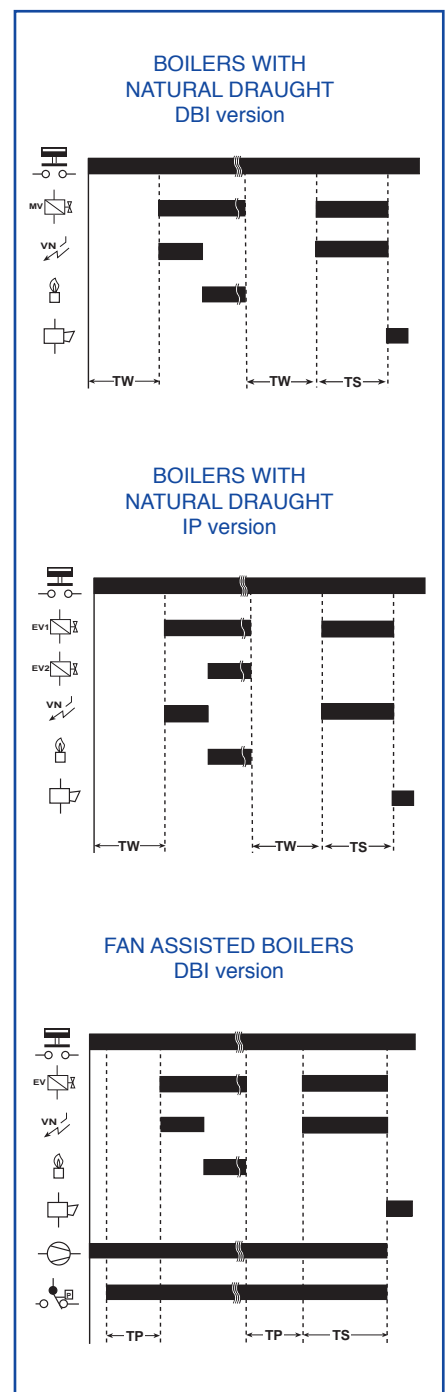
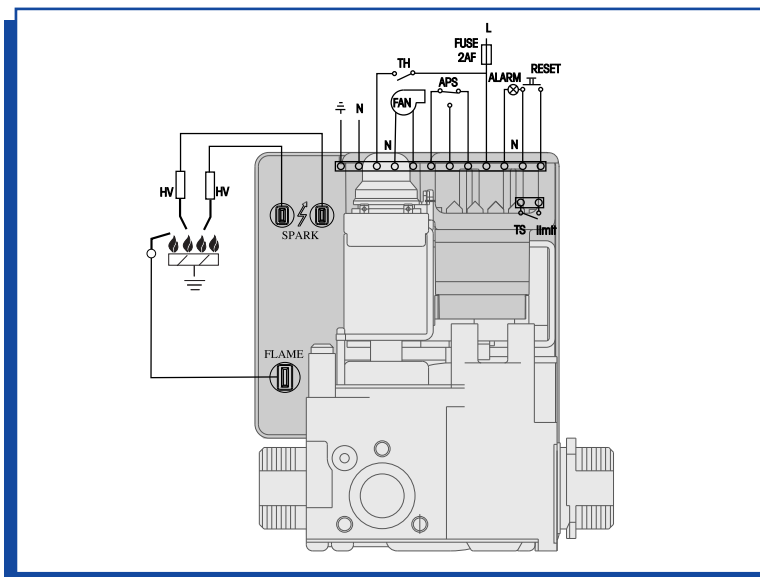

TECHNICAL DATA

AMBIENT WORKING TEMPERATURE

-20 TO + 60 °C

HUMIDITY

95 % max at 40 °C

SUPPLY VOLTAGE

230 Vac - 15 %, + 10 %, 50-60 Hz

POWER CONSUMPTION

10 VA

ELECTRICAL RATINGS

Gas valves: 230 Vac, 0,5 A, $\cos\varphi\geq 0,4$

Fan: 230 Vac, 1 A, $\cos\varphi\geq 0,4$ (optional)

Allarm: 230 Vac, 1 A, $\cos\varphi=1$

ELECTRICAL CONNECTIONS

High voltage probe: male fast-on connector 2,8 mm X 0,5 mm

Flame detection probe: male fast-on connector 4,8 mm X 0,8 mm

Other connections: male Molex series 2599 suitable for female Molex series 3001 and 3002 or compatible.

PROTECTION DEGREE

Standard IP 40

IP 44 with gaskets

TIMING

Minimum waiting time T_w or purge time T_p : 1,5 ... 40 sec.

Maximum safety time T_s : 3 ... 60 sec.

FLAME SENSING

Minimum flame current: 0,5 μ A

Recommended flame current: > 3 times the minimum current

FUSING

Internal: 4A fast.

External: 3,15A fast or less depending on the electrical loads. This fuse protects the device in the event of overloading or short circuits and prevents the intervention of the internal fuse.

IGNITION

Ignition voltage: 15 KV at 30 pF load

Repetition rate: 25Hz standard (1 \div 25 Hz)

Max. length of the cable: 2 m

Spark gap recommended: 2-4 mm

MOUNTING

Integrated on SIT SIGMA multifunctional gas controls.

DIMENSIONS- 537 ABC with 845 SIGMA VERSION G3/4 ISO 228

